



250 Industrial Tower

Single Width Tower Assembly Guide

Product Information and Assembly Guide

Single Width Tower Assembly Guide

This document will provide all users of Lewis Access Towers with a complete guide to the erection of the Lewis SW (Single Width) Aluminium Tower, employing the 3T (Through the Trap) method.

The user should read the entire contents of this document before commencing assembly and pay particular attention to all of the safety instructions. If the equipment is passed onto another party a copy of these instructions should accompany the handover.

Two persons are necessary to carry out the erection of the equipment detailed in this document. It is strongly recommended that the following items of personal protection equipment be worn at all times: safety boots (EN345 or BS1870 / 4972); safety helmet (EN397 or BS5240); gloves. The SWL (Safe Working Load) for each platform is 275kg, evenly dispersed.

The Lewis Tower is a Class 3 Industrial Tower System

The tower should be manoeuvred into position by hand by pushing it from the base frame. Never attempt to use any mechanical equipment (i.e. a forklift etc.) to move the tower.

If it is necessary to lift individual components whilst assembling the tower, a dependable knot should fasten each item.

Be aware of overhead obstructions – pay particular attention to any live electrical cables. Ensure that no persons, materials or tools are on the tower when it is being moved.

Additional care should be taken when moving the tower on uneven or inclining ground. The use of the castor locks should be deployed when the tower is in position. When moving the tower the stabilisers should only be lifted 35mm from ground level.

Towers under 4m in height are the only towers that should be moved.

- Check all components (see component list) are available and in usable condition.
- Damaged or incorrect components should not be used.

Working on the Tower - The Beaufort Windscale

Scale 4. 13 - 18 mph **OK TO WORK ON TOWER**

Moderate Breeze: Raises dust, loose paper; moves small branches

Scale 5. 19 - 24 mph **STOP WORKING ON TOWER**

Fresh Breeze: Small trees in leaf begin to sway; white crested wavelets form on inland waters

Scale 6. 25 - 31 mph **DISMANTLE TOWER**

Strong Breeze: Large branches in motion; umbrellas used with difficulty; telephone wires "whistle".

Be aware that wind conditions are a very important consideration when using a tower. Attention must be paid to individual situations where wind conditions can increase - i.e. when working between buildings, or close to the corner of a building and at open ends.

Never use tarpaulins or similar covers without seeking the correct advice.

Additional items, such as steps or conventional ladders, must never be used to gain further height from the platform. The tower must be climbed from within the structure, on no occasions should the tower be scaled from the outside. Inspect all the tower components before each use. Pay particular attention to;

- Castings - check for cracks
- Welds - free from cracks
- Tubes/Braces/Rungs - Straight and with indents less than 5mm deep
- Platforms - no damage, free from debris
- Castors - moves freely, threads free from damage, brake working
- Outriggers - straight, feet flat
- Inspect the equipment for damage regularly, at least daily.

- If damage should occur whilst in use, stop work immediately and isolate the damaged items from the rest of the tower and contact your supplier.
- Check the ground on which the tower is to be used is relatively flat, smooth and capable of supporting the tower.
- The SWL (Safe Working Load) of the tower is 275kg per platform, inc the weight of the tower - evenly distributed, up to a maximum of 950kgs per tower.
- Do not exceed the SWL.
- Never attach safety harnesses or similar safety equipment to the tower whilst erecting or dismantling the tower.
- During assembly, the tower should only be climbed from inside of the frame dimensions, do not scale the tower from the outside.
- Tools and equipment must be loaded onto the platform within the confines of the tower dimensions.
- Adjustable legs are to be used for levelling.
- Outriggers should always be deployed when required.

If the area of operation means that the outriggers cannot be deployed in the recommended position – contact Lewis Towers or your supplier for advice.

Ballast for Towers up to 12.2m in height, ballast is not necessary

SINGLE WIDTH INTERNAL AND EXTERNAL USE

Working Height in (m)	3.2	3.7	4.2	4.7	5.2	5.7	5.2	6.7	7.2	7.7	8.2	8.7
Platform Height in (m)	1.2	1.7	2.2	2.7	3.2	3.7	4.2	4.7	5.2	5.7	6.2	6.7
150mm Castor	4	4	4	4	4	4	4	4	4	4	4	4
Adjustable Leg 500mm	4	4	4	4	4	4	4	4	4	4	4	4
4 Rung 1m Frames		2	2			2	2			2	2	
6 Rung 1.5m Frames		2		2		2		2		2		2
8 Rung 2m Frames	2		2	2	4	2	4	4	6	4	6	6
1.8m / 2.5m Fixed Deck	1	1	1	1	2	2	2	2	2	2	2	3
1.8m / 2.5m Trap Deck	6	6	6	6	10	10	10	10	10	10	10	14
1.8 m / 2.5m Horizontal Brace	2	2	3	4	5	6	7	8	9	10	11	12
2.1 m / 2.7m Diagonal Brace	2	2	2	2	2	2	2	2	2	2	2	2
1.8m / 25mm Side Toe Board (Wood)	2	2	2	2	2	2	2	2	2	2	2	2
1.2m End Toe Board (Wood)	4	4	4	4		4	4	4	4	4	4	4
Toe Board Clip	0	0	4	4		4	4	4	0	0	0	0
Standard Stabilisers	0	0	0	0		0	0	0	4	4	4	4
Jumbo Stabilisers	0	0	0	0		0	0	0	0	4	4	4
Total Self Weight of Tower (Kg) - 1.8m	74	77	101	107	138	146	151	160	167	176	180	215
Total Self Weight of Tower (Kg) - 2.5m	83	86	110	117	153	163	168	177	184	194	198	240

Working Height in (m)	9.2	9.7	10.2	10.7	11.2	11.7	12.2	12.7	13.2	13.7	14.2
Platform Height in (m)	7.2	7.7	8.2	8.7	9.2	9.7	10.2	10.7	11.2	11.7	12.2
150mm Castor	4	4	4	4	4	4	4	4	4	4	4
Adjustable Leg 500mm	4	4	4	4	4	4	4	4	4	4	4
4 Rung 1m Frames		2	2			2	2			2	2
6 Rung 1.5m Frames		2		2		2		2		2	
8 Rung 2m Frames	8	6	8	8	10	8	10	10	12	10	12
1.8m / 2.5m Fixed Deck	3	3	3	3	3	3	3	4	4	4	4
1.8m / 2.5m Trap Deck	14	14	14	14	14	14	14	14	18	18	18
1.8 m / 2.5m Horizontal Brace	13	14	15	16	17	18	19	20	21	22	23
2.1 m / 2.7m Diagonal Brace	2	2	2	2	2	2	2	2		2	2
1.8m / 25mm Side Toe Board (Wood)	2	2	2	2	2	2	2	2		2	2
1.2m End Toe Board (Wood)	4	4	4	4	4	4	4	4		4	4
Toe Board Clip	0	0	0	0	0	0	0	0		0	0
Standard Stabilisers	4	4	4	4	4	4	4	4		4	4
Jumbo Stabilisers	4	4	4	4	4	4	4	4		4	4
Total Self Weight of Tower (Kg) - 1.8m	252	286	315	271	277	286	290	326	332	339	346
Total Self Weight of Tower (Kg) - 2.5m	278	313	342	304	312	321	326	366	374	381	388

Single Width Tower Assembly Instructions

1.1 Prepare the frame for assembly.



1.2 Insert the Adjustable Leg, and then the castor into the bottom of the frame.



1.3 Prepare the frame adjacent to the frame in 1.2.

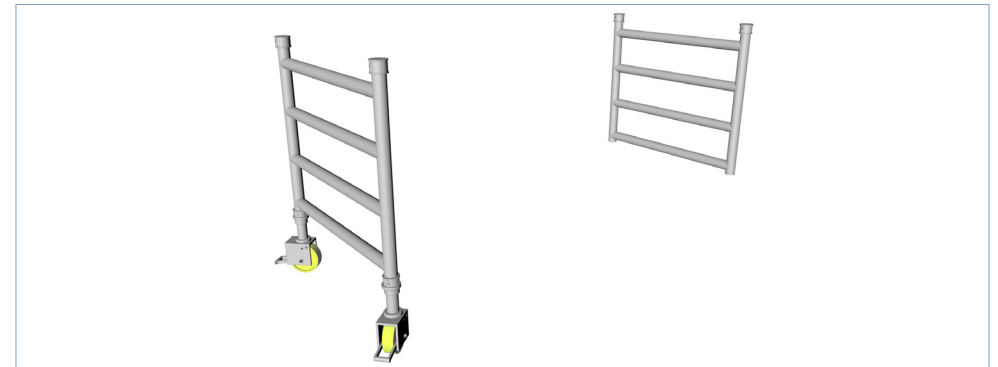

1.4 Insert the adjustable leg, then the castor into the bottom of the frame.



1.5 Clip the horizontal brace onto the frame. Connect the brace directly above the casting at the first horizontal rung position.

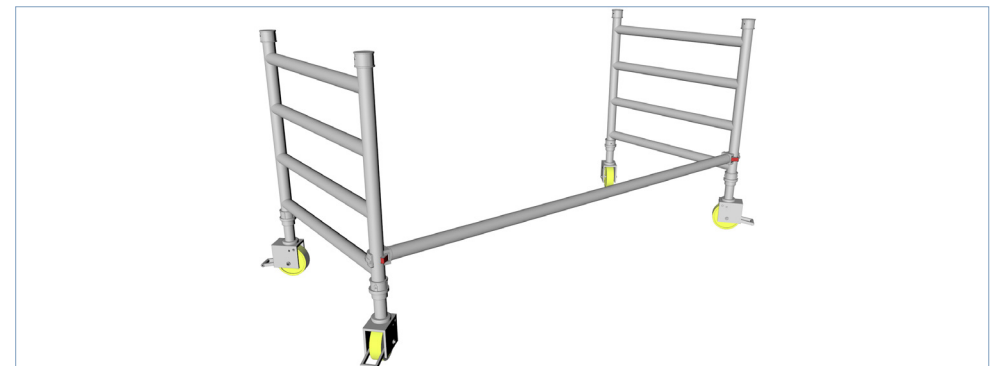

1.6 Clip the second brace in the same position, on the other side of the frames. Make sure the base is level using a spirit level. Any alterations needed, can be adjusted on the legs.

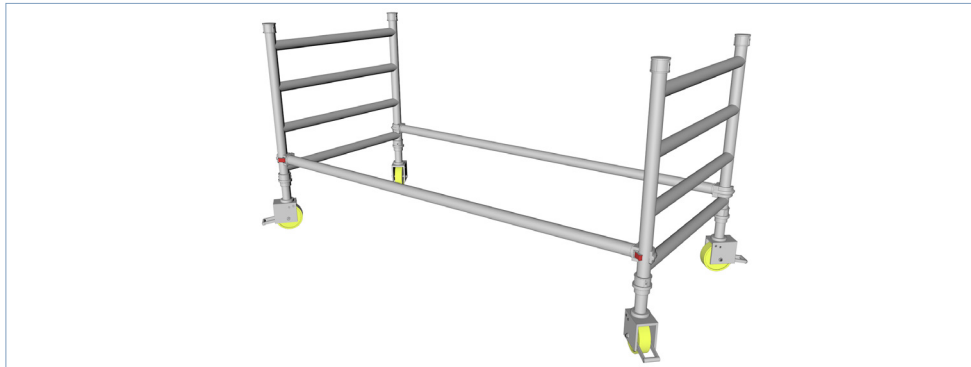

1.7 Make sure the Trigger is facing the outside of the frame.

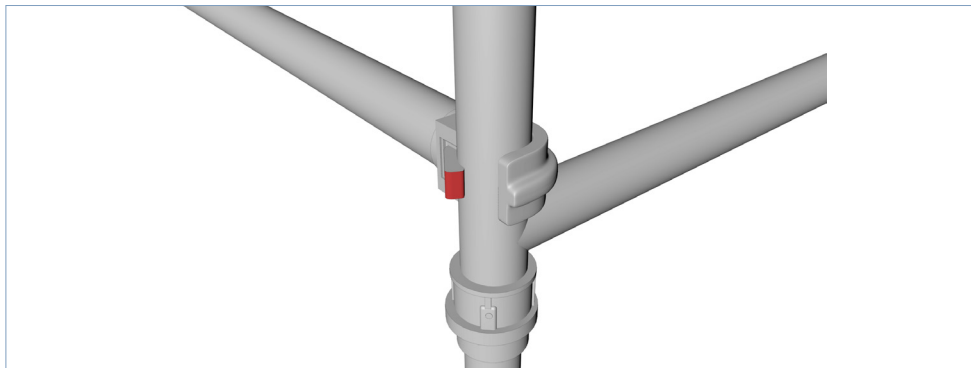

1.8 Insert the next section – this may vary in size depending on which tower you have. However, the image we have used, is an 8 Rung (2m high) frame.



1.9 Clip the diagonal braces onto the lowest rungs.



1.10 Insert the adjacent frame.



1.11 Clip the diagonal braces onto the lowest rungs.



1.12 When fitting the stabilisers, position each one in opposing directions, Adjust all four castors to ensure the tower is square and level – You can use a spirit level here to check.

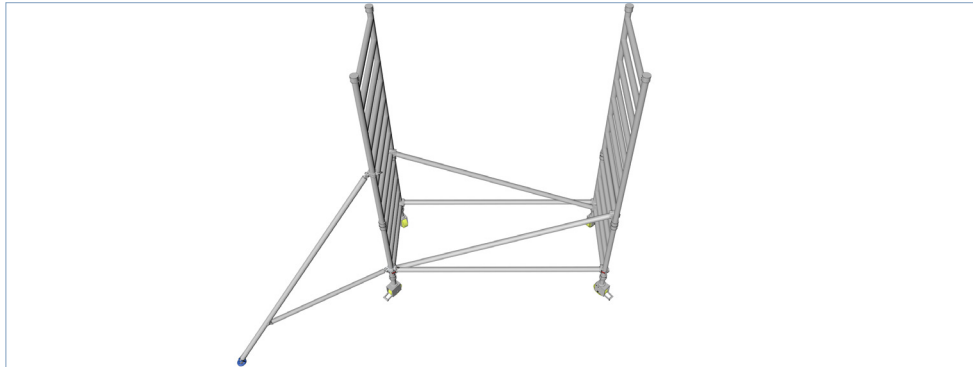

1.13

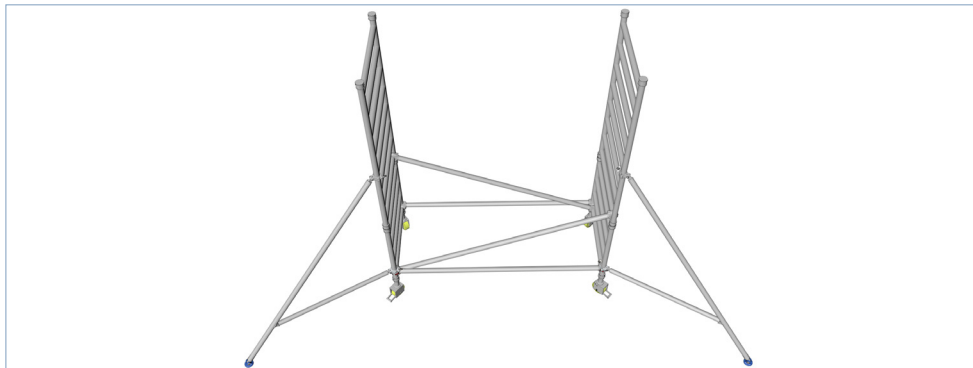

1.14

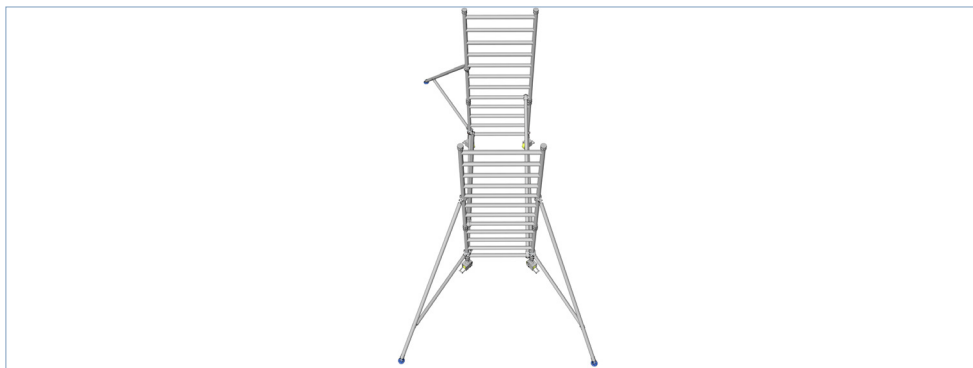

1.15

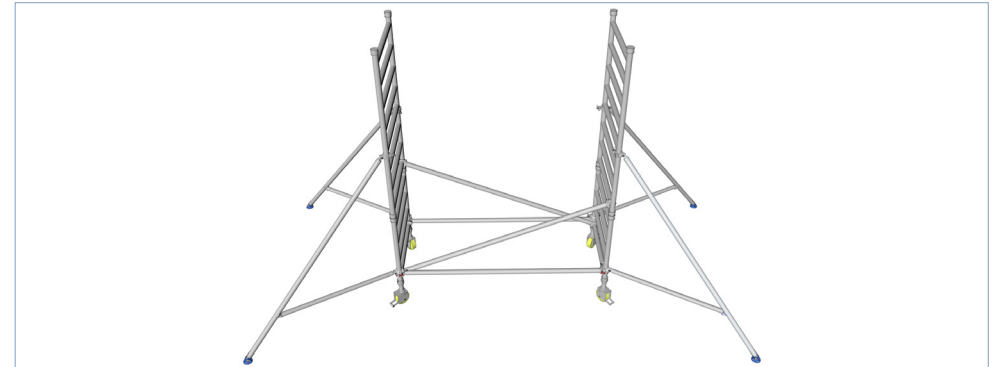

1.16 Stabilisers must be in opposing directions to ensure full stability of tower.

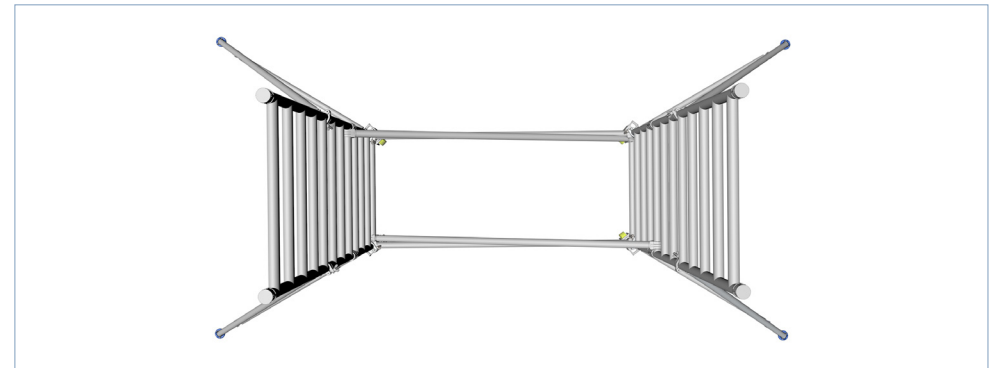

1.17 Ensure spring clips are located in the locked position.

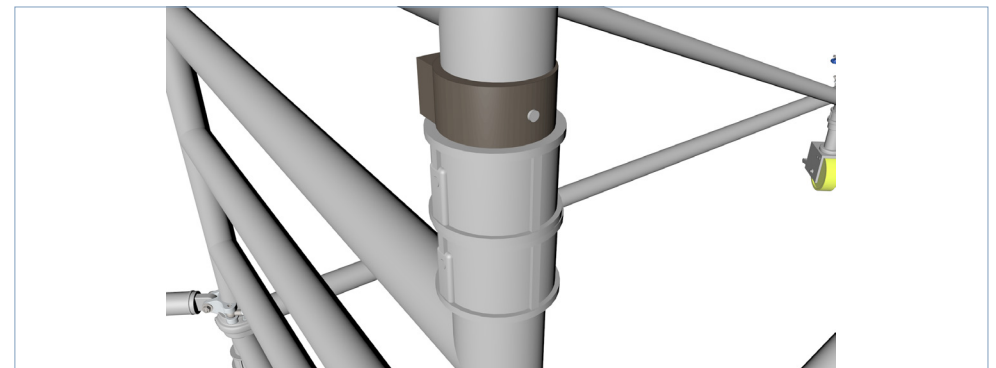

1.18 Attach the trap door platform approx. 2.2m above ground level. This will be on the 8th Rung, if you started to build the tower with an 8 Rung Section. If you started to build the tower with the 4 Rung (1m) frames, then the 1st platform will be placed approx. 4 Rungs above the frames. This will vary depending on what section you have started to build your tower with.

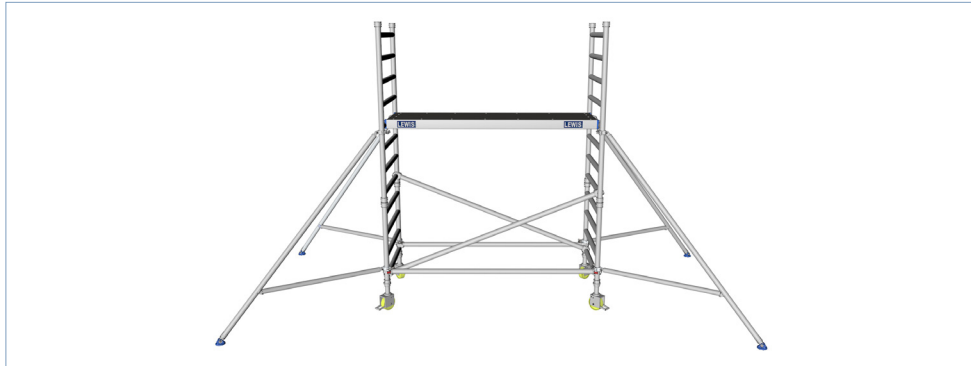

1.19 Align the platform evenly between the frame.



1.20

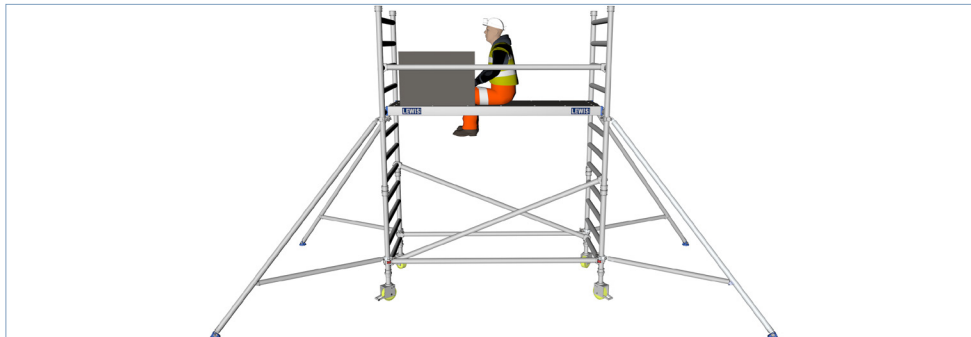

1.21 Climb internally up the rungs of the frame through the trap door platform. site with feet through the platform, so they are resting on the rung of the frame. Fit four guardrail braces on the 2nd Rung and 4th Rung above the platform. or at approx. 250mm above the platform, then a further 250mm from there.

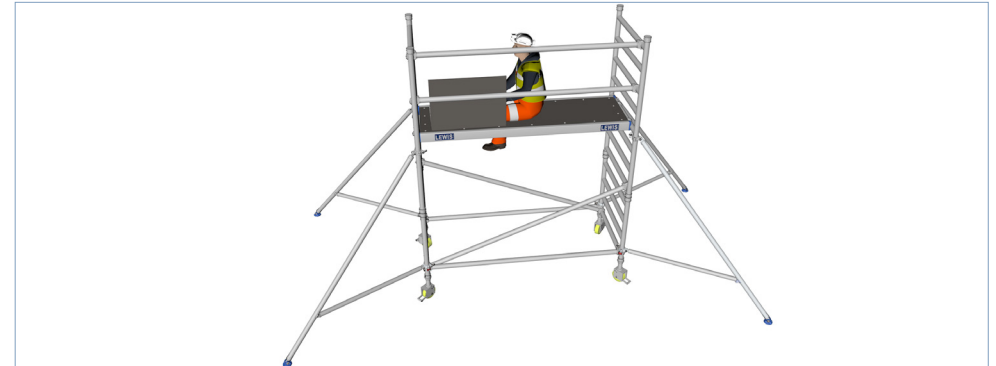

1.22 Ensure at this point the diagonals are also in place.



1.23

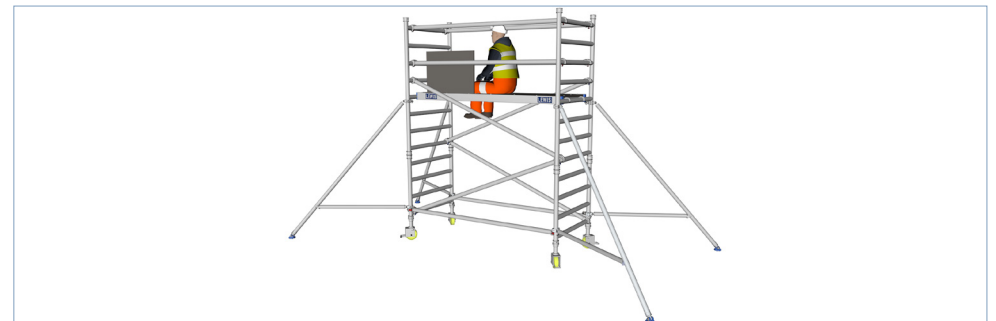

1.24 Here a 2.2m Platform Height tower has been built.



1.25 To continue to build higher – insert your next level of frames (the size may vary depending on what tower you have) our images show an additional 2m, 8 Rung section.



1.26 Stand on platform and ensure the guardrails are securely in place at the opposite end of the tower.

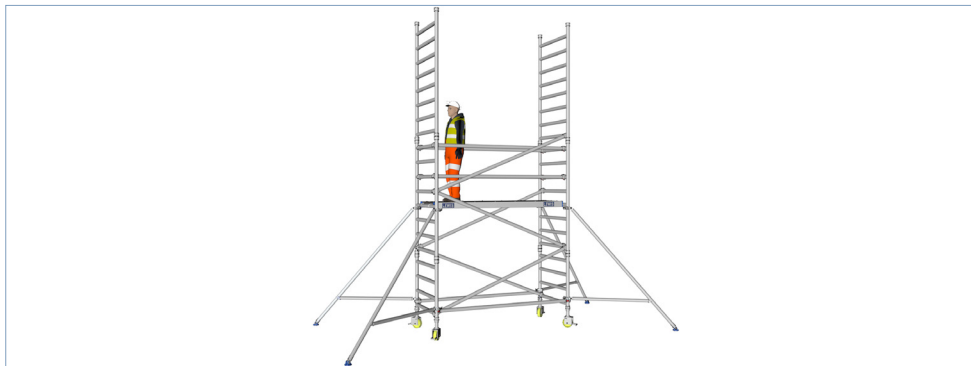

1.27 Ensure the frame locking clips are securely in place.

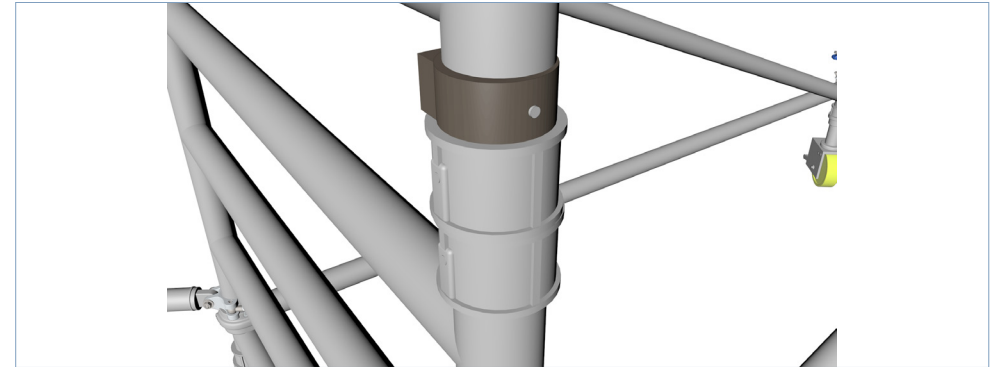

1.28 Place the trap door platform approx. 2m above where you are standing. The platform should now be placed approx. 4.2m off the ground. Our images show, the second platform is placed at a 4.2m platform.



1.29 Climb through your trap door platform, with feet resting on the rung below.



1.30 Put the handrails in the correct place. The first will be placed approx. 250mm from the platform, (the 2nd rung above the deck) and then again at 500mm (the 4th rung above the deck).



1.31

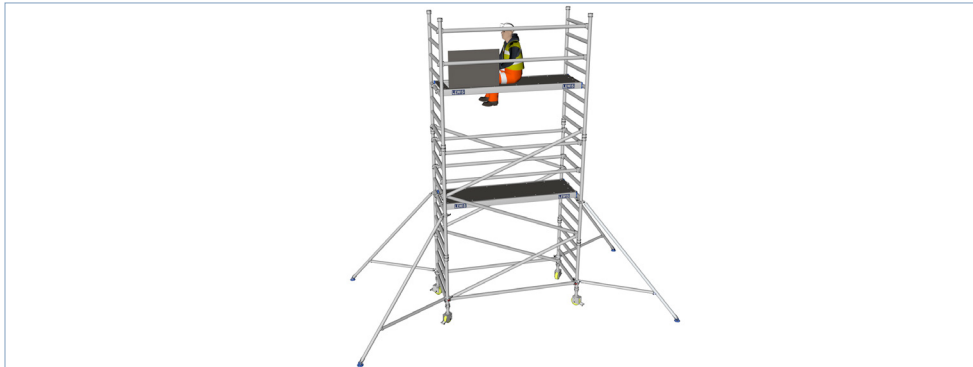

1.32



1.33 Stand on the platform to inspect and check the braces are all securely into place, and facing the correct way.

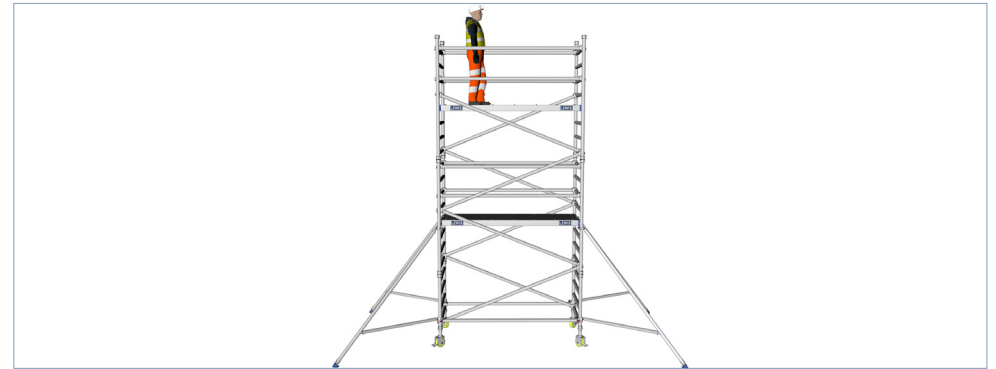

1.34 Put the toe board set in place. Place the 4 x Toe Board Clips, in al 4 corners of the platform, then place the wood.



1.35 The image is now showing a 4.2m platform height tower built.



Dismantling

To dismantle the LEWIS single width tower, first remove the toeboard set and send safely down the tower. Remove the furthest of the four guardrails and diagonal brace. Go directly to the trapdoor platform next to the ladder frame to remove the braces completely. To fully dismantle the tower reverse the erection procedure detailed in this guide above.

Stability

Towers left unattended or unused for extended periods in exposed situations should be dismantled. Horizontal forces i.e. pressure exerted when drilling into a building face can yield instability in the tower. The tower must not be used to gain access to a neighbouring structure. Tower are not intended to be suspended.

Transport and Storage

Components should be transported and stored vertically. Damaged items must be repaired by a competent person. Contact your supplier for advice.



Further Information

For further information and support please contact us on:

0800 043 2222
info@scaffold-tower.co.uk
www.scaffold-tower.co.uk

Unit 1 Bellingham Trading Estate
Fanthorne Way
London
SE6 3BX

